

Schalldruckpegel $L_A (dB) = \text{Schall-Leistungspegel } L_W \text{ (aus Diagramm) minus 19 dB}$

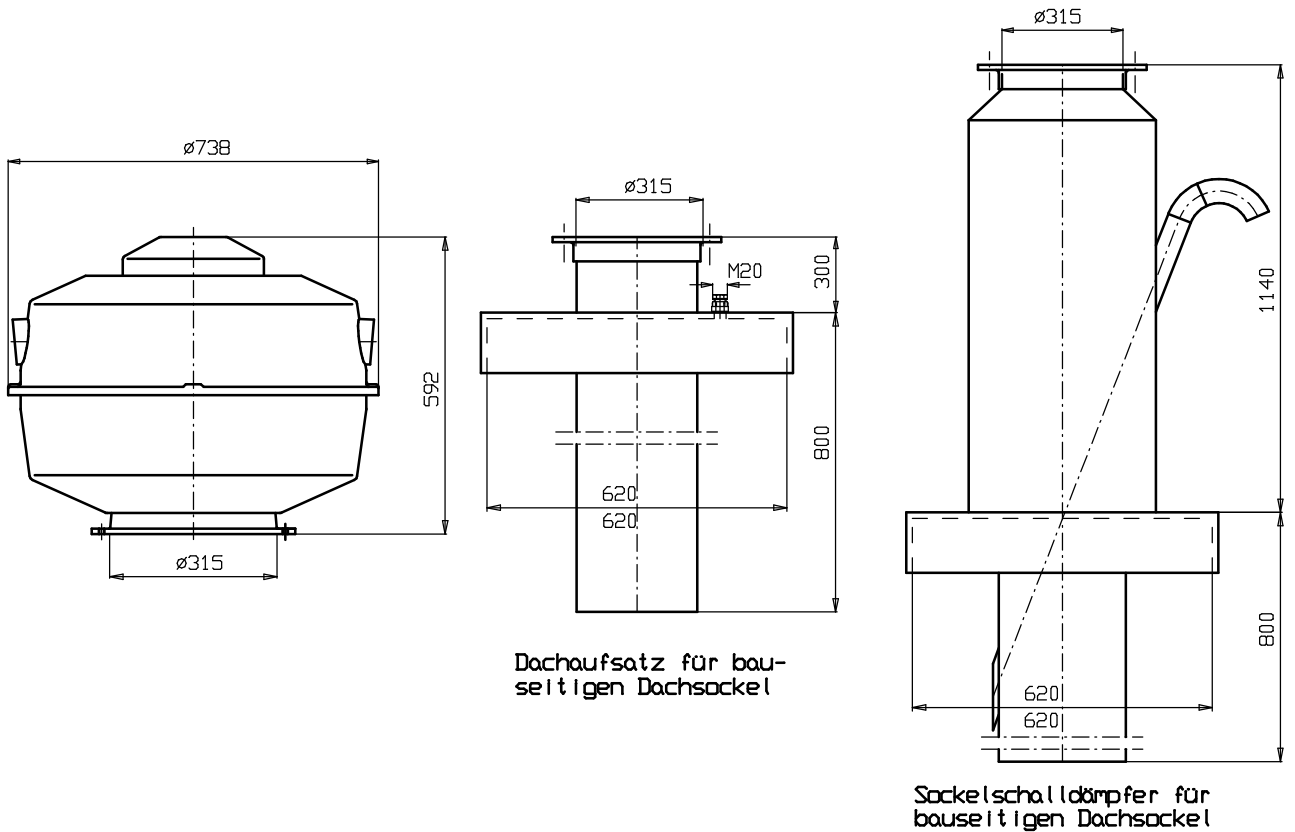

Maßänderungen vorbehalten