

High performance radial fans Series ML 160 to 400



Operating Instructions 01/2013

Introduction	1
Manufacturer and suppliers	2
Declaration of conformity	3
Subject matter of the operating instructions	4
Symbols used	5
Safety instructions	6
Product description	7
Planning use	8
Installation and assembly	9
Commissioning	10
Operation	11
Maintenance, cleaning and repair	12
Warranty	13
Appendices A.x	Ax

Table of contents

1	Introduction	5
2	Manufacturer and suppliers	6
2.1	Manufacturer.....	6
2.2	Customer service.....	6
2.3	Suppliers.....	6
3	3Declaration of conformity	7
3.1	EU Declaration of Conformity within the meaning of the EU Machinery Directive (2006/42/EU), Low Voltage Directive 2006/95/EU and EMC Directive 2004/108/EU	7
4	Subject matter of the operating instructions	8
5	Symbols used	8
6	Safety information	9
7	Product description	11
7.1	Fan design	11
7.2	Fan materials	12
7.3	Proper intended use	13
7.4	Improper use.....	13
7.5	Technical Data	14
7.6	Labelling.....	15
7.7	Power supply	16
8	Planning use	16
8.1	Transport.....	16
8.2	Storage	16
8.3	Disposal	17
9	Installation and assembly	17
9.1	Electrical connections	18

10	Commissioning	18
11	Operation	19
11.1	Troubleshooting	19
12	Maintenance, cleaning and repair	21
12.1	Maintenance and cleaning.....	21
12.2	Performing maintenance work.....	22
12.3	Repair	24
13	Warranty / guarantee	24

Appendices

A.1	Maintenance checklist	26
A.2 to A.10	Performance data	28
A.11	Scope of delivery	37
A.12	Notes	43

1 Introduction



These operating instructions

- are to be considered part of the product, and
 - are to be read carefully and thoroughly by the operator/s of the fan/s before first use of same.
-
- The safety information contained herein must be adhered to.
 - The operating instructions are to be passed on to subsequent owners and operators of the equipment.
 - Please contact Joh. Mueller Kunststoff GmbH if you have any queries. Do not operate a fan if there is any doubt as to its proper condition or assembly.
 - This fan may only be assembled, installed and operated by properly qualified persons.
 - Note the symbols used drawing attention to specific risks and supplying information on same.
 - The operating instructions for the motor must also be adhered to and are a major part hereof.
 - No liability whatsoever can be accepted for damage due to disregarding the operating instructions.
-

2 Manufacturer and suppliers

2.1 Manufacturer

Joh. Mueller Kunststoff GmbH

Lescheider Weg 6-8

53773 Hennef-Bierth

Germany

Tel.: +49-2248-9173-0

Fax: +49-2248-9173-79

Internet: www.kunststoff-mueller.de

2.2 Customer Service

Joh. Mueller Kunststoff GmbH

Lescheider Weg 6-8

53773 Hennef-Bierth

Germany

Tel.: +49-2248-9173-0

Fax: +49-2248-9173-79

Internet: www.kunststoff-mueller.de

2.3 Suppliers

See the appendix on scope of delivery A.11

3 Declaration of conformity

3.1 EU Declaration of Conformity within the meaning of the EU Machinery Directive (2006/42/EU), Low Voltage Directive 2006/95/EU and EMC Directive 2004/108/EU

Joh. Mueller Kunststoff GmbH, Lescheider Weg 6-8, D-53773 Hennef-Bierth, declare that the machine described below complies in its design and construction and in the version marketed by them with the applicable health and safety requirements of the EU Machinery Directive and the requirements of the EMC and Low Voltage Directives. This declaration becomes invalid should the machinery be modified without our consent.

Machine description: Radial fan
Machine type: Series ML 160 to 400
Machine no.: See Appendix A.11

Relevant EU Directives

Directive / standard	Text
2006/42//EU	EU Machinery Directive - Directive of the European Parliament and Council on Machinery
2006/95/EU	Low Voltage Directive
2004/108/EU	Electromagnetic Compatibility Directive
Harmonised standards applied:	
DIN EN ISO 12100	Safety of Machinery - General Design Principles - Risk Evaluation and Risk Reduction
DIN EN ISO 13857:2008	Safety of Machinery - Safety Spacing to Prevent Proximity to Danger Areas of Upper and Lower Extremities
DIN EN 62079 2001	Drafting instructions - classification, content and presentation
prEN 14461 2002	Industrial fans - safety requirements
Applied national standards and technical specifications	
VDMA 24 167 1994	Fans; safety requirements

Name and address of the person authorised to put together the technical documentation:
 Thomas Scheffler, Joh. Mueller Kunststoff GmbH, Lescheider Weg 6-8, D-53773 Hennef-Bierth

Hennef-Bierth, 27 May 2013











Thomas Scheffler, Managing Director

4 Subject matter of the operating instructions

The operating instructions only apply to the fan/s supplied including assembly frame/s and motor/s. The interfaces are the sleeves for connection to the piping system.

5 Symbols used

	Caution Non-compliance may result in injury or damage.
	Note Important information
	Prohibition!
	Danger due to electricity.
	Hot surface
	Risk of crushing
	Risk of ingestion
	General instruction (e.g. wear protective clothing)
	Release before performing any work

6 Safety instructions



As operator you're responsible for

- ensuring fans are only used if in technically problem-free condition, only for their intended purpose and in compliance with these operating instructions.
- Ensuring staff are aware that proper use includes adherence to the maintenance requirements.
- Ensuring technical and safety familiarisation of staff with the equipment. Staff knowing the operating instructions.
- Ensuring fan operation conditions are adhered to.



The fans can be operated up to a maximum ambient temperature of 40° C and in the temperature ranges in **Table 2** with the pumping media. At operating temperatures exceeding the maximum permissible (see **Table 2**) the operator must determine and then exclude additional risks.



Fan RPM can be safely limited (see scope of delivery in Appendix A.11 – Maximum Permissible RPM).



Protective clothing must be worn when performing assembly, repair or maintenance work on a fan.



Electric power connection/s must be installed by a qualified electrician.



The motor must be electrically dead before work is carried out on a fan and also protected against unauthorised / unintentional switching on by a maintenance switch with lock.



The fan has no shaft bushing and cannot be considered leakproof; absolute leakproofing cannot be guaranteed and this includes flange connections.



Pumping media that may involve contamination make an upstream filter or mist eliminator essential.



The fans ought to be installed in separate rooms for noise abatement reasons.



People should stay away from the fans, particularly the housings.



The conformity declaration is rendered invalid if a fan is modified by e.g. adding a frequency converter or metrology equipment, and the operator must then declare conformity themselves after risk analysis.



Fluid drainage in the spiral housing must be continuous. The atmosphere in the interior must not leak out, e.g. through immersion or use of a siphon.



Earth the fans using the earthing points provided.

7 Product Description

7.1 Fan design

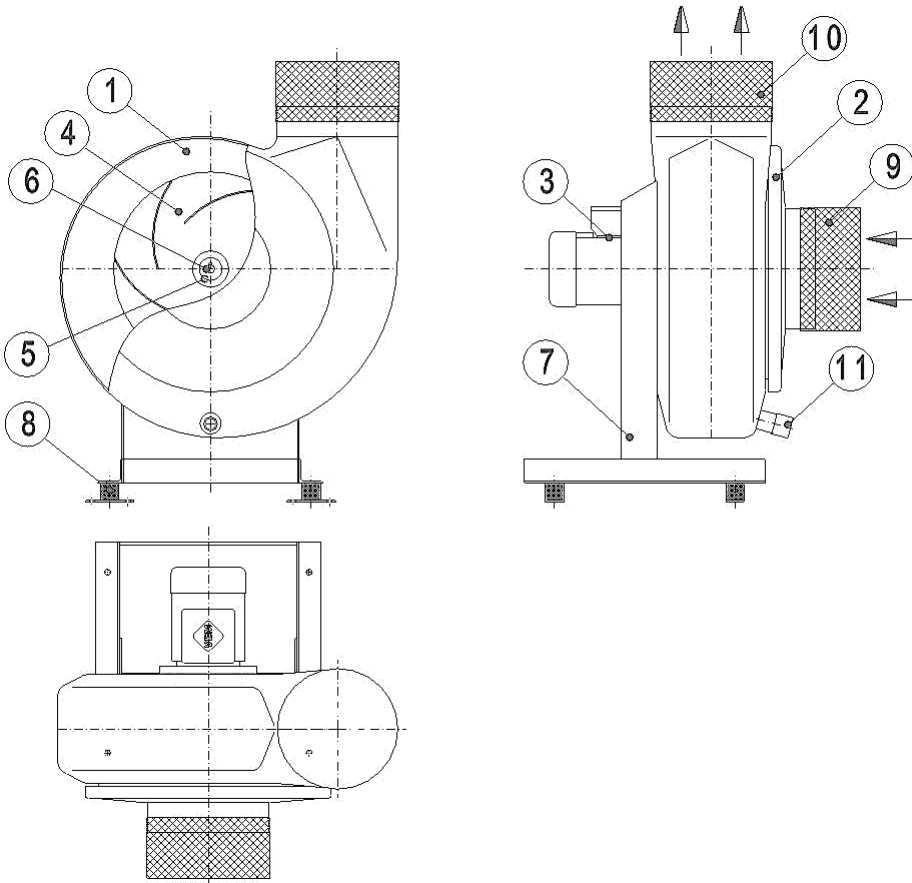

Illustration 1: Radial fan, type series ML 160 to 400

Item	Description	Item	Description
1	Fan housing	7	Fan block of steel including means of connection for earthing or potential equalisation .
2	Nozzle cover	8	Vibration dampers (4 pcs.)
3	Motor	9	Bushing, suction side
4	Rotor	10	Bushing, pressure side
5	Clamping sleeve	11	Condensation drain
6	Motor shaft		

Joh. Mueller Radialventilatoren series ML 160 to 400 are radial fans with suction on one side. Gaseous media are sucked in axially to the drive axle, redirected by rotor movement by 90 degrees and radially expelled.

The fans consist of housing, rotor, assembly frame of sectional steel and the drive motor. The radial fans of the ML 160 to 400 series are supplied with direct drive as standard (design D) with the rotor directly connected to the drive motor shaft.

The housings of radial fans of the ML 160 to ML 315 series are made of deep drawn thermoplastic; those of the ML 355 to 400 series are welded; all fans have shatter protection. A condensate drain pipe is installed at the lowest point of the housing. Possible housing settings are named per VDMA 24165.

The housing has a cover to make installation and removal of the rotor and maintenance and repair possible ; from series ML 355 an inspection hatch is also provided.

The special ML 0160, 0180 and 0200 series differ from standard only in having smaller rotors and inlet nozzles.

The rotor in the ML 160 to 400 series is made of thermoplastic and statically and dynamically balanced per G6.3 VDI (Association of German Engineers).

The fans in the ML 160 to 400 series do not have shaft bushing as standard.

Data on radial fans supplied including drive motor/s is contained in Appendix A.11.

7.2 Fan materials

The permissible total temperatures of the thermoplastics used are as below.

Plastic	Temperature range min. / max.	Plastic	Temperature range min. / max.
PVC	0 °C to +50 °C	PE	-20 °C to +60 °C
PP/ PPS	-20 °C to +70 °C	PVDF	-10 °C to +100 °C

Table 1: Temperature range of the plastics used

The total temperatures the plastics used can stand may not be exceeded or undercut. At temperatures below zero the risk of fracture increases if mechanically loaded.



The maximum ambient temperature for drive motors is 40 °C.

7.3 Proper use



The radial fans in the ML 160 to 400 series are intended for use in pumping gaseous media free of dust.

Radial fans of the ML 160 to 400 series are solely intended for use in piping systems. Before using them it must first be determined that the entire plant concerned complies with EU Machinery Directive RL2006/42/EU.

The operating conditions below must be adhered to.

		Fan vicinity	Pumped media
Temperature	Min. Max.	> -20 °C < 40 °C	For the plastics PP/PPS/PVDF > 0 °C < 60 °C For the plastic PE > 0 °C < 50 °C For the plastic PVC > 0 °C < 40 °C
Min./max. pressure			+/- 30 mbar overpressure

Table 2 Operating conditions



If gas inlet temperatures exceed those above the operator must check the possible risks incurred and exclude same.

7.4 Improper use



The radial fans of the ML 160 to 400 series may not be used in areas at risk of explosion classified as Zone 1 or 2 and may not be installed in said zones. They are not suitable for pumping dust, poisonous vapour or media that corrode the fan material.



In areas where high dust contamination prevails cleaning intervals must be shortened appropriately.



Do not use improperly.

7.5 Technical data

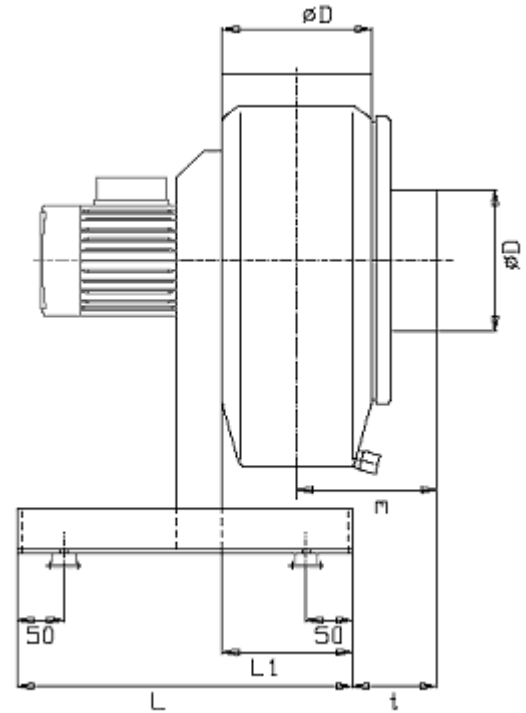
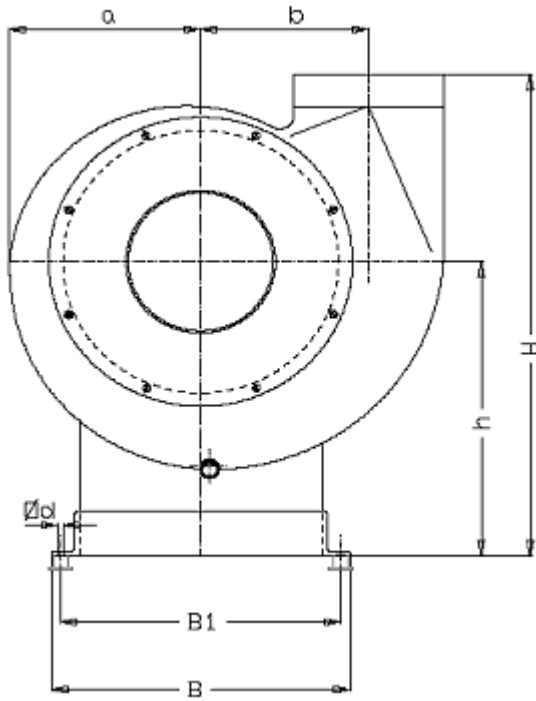

Type (ØD)	L	L ₁	B	B ₁	H	h	a	b	t	Ød	m	Max. kg
ML-160	360	140	340	300	540	330	205	180	90	9	150	19
ML-180	400	180	374	300	620	355	250	222	70	9	160	21
ML-200	400	180	374	334	620	355	250	212	90	9	170	22
ML-225	440	220	402	362	700	430	270	246	74	9	185	23
ML-250	440	220	402	362	700	430	270	234	90	9	190	25
ML-280	500	280	432	392	800	480	310	280	50	9	210	31
ML-315	500	310	468	428	884	544	363	327	130	9	230	37
ML-355	715	242	500	460	1148	599	417	369	88	9	325	62
ML-400	785	272	570	530	1281	661	468	415	108	9	340	80

The right to make changes is reserved.

Table 3: Radial fan technical data

Possible alignments for fans of the ML series. The GR alignment is shown (GL is the mirrored design).

GR 360

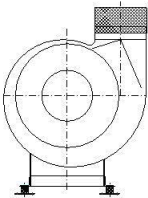

GR 90

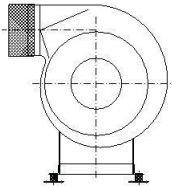

GR 180

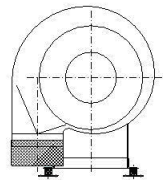

GR 270

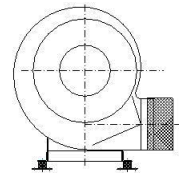

7.6 Labelling

The following data characterise the fan type, performance and uses and hence the proper use.

Type plate data.

JOH. MÜLLER		Lescheider Weg 6-8 • 53773 Hennef	
KUNSTSTOFF GMBH		Telefon 0 22 48-91 730 • Fax -91 73 79	
Type:	ML-...		
Baujahr:		Motordrehzahl:	UpM
Geräte Nr.:		Motorleistung:	kW
Teilenummer		Nennspannung:	V
Volumenstrom:	m ³ /h	Nennstrom:	A
Gesamtdruck:	Pa	max. Drehzahl:	UpM
T außen:	-20 ... +40 °C	T innen:	0 – 60 °C
min./max. Druck	± 30 mbarü	Wirkungsgrad:	%
Schalldruckpegel:	--- dB(A)		
CE			



Type plate and warnings must always be legible. If it is ascertained during maintenance that they are illegible or missing then they must be cleaned or replaced.

Type plate data for the radial fan supplied is given in Appendix A.11.

7.7 Electricity supply

A terminal box or maintenance switch can be supplied to connect the fan to the electricity supply as desired. A maintenance switch can be provided to switch the fan electrically dead when carrying out maintenance and repair work (see scope of delivery in Appendix A.11).

8 Planning use

8.1 Transport

Joh. Mueller radial fans are supplied pre-assembled in sealed foil packaging on a pallet ex works. The vibration dampers accompany each fan as separate items.

Check on receipt of the goods whether the fan/s has/have suffered shipping damage as later complaint cannot be accepted. Pay close attention to motor installation and rotor shaft.



Move the fan with care as plastics are sensitive to shocks and impacts at low temperatures.



The fan can be moved with a forklift under it or using other suitable lifting equipment. The load must be so secured that the fan cannot slip or tip.



If transported on a lorry fans must be secured against tipping, falling over, moving etc.



Check lifting equipment beforehand.



The weights in **Table 3 7.5** are to be adhered to.

8.2 Storage

The fan/s must be stored in closed dry rooms where as even a temperature as possible prevails. This must be above 0 °C and below 40 °C. Avoid direct sunlight, high humidity and dusty, corrosive atmospheres and substances, vibrations and shocks.



If stored or turned off for a long time the shafts must be turned once a year to keep them rotatable. Adhere to the motor information given in the operating instructions.

Please also refer to the motor operating instructions.

8.3 Disposal

Please commission a disposal company to dispose of the equipment properly. Currently valid environmental law must be observed.

Before disposal clean the components to prevent their presenting any environmental risk or danger to persons.

Observe environmental rules during disposal.

9 Installation and assembly



Installation and assembly of the radial fans should only be carried out by properly qualified staff of Joh. Mueller Kunststoff GmbH or specialists commissioned by the client for the purpose.



Before installing the fan/s operators must ensure the floor and/or ceiling load capacity is adequate and that it/they is/are suitable for the stress and strains exerted by the radial fan unit/s.

- Before the fan unit/s is/are installed the operator must ensure all due allowance has been made for ambient conditions of same (plastics, motor, electrical components).
- The fans must be installed on a flat surface using vibration dampers and aligned horizontally.
- The operator must make all due allowance for fan noise when siting them. They ought preferably to be installed in separate rooms for noise abatement reasons.
- Before connecting them to the power supply turn the rotor to ensure it moves freely.
- Install piping. If the scope of the commission doesn't include piping installation then this must be done by the operator.
- Piping connections must be flexible. Suction inlets and pressure outlets may not be mechanically stressed by piping connections.



Fans may not be operated when uninstalled.

- When installing fans make sure the motor ventilation apertures remain unobstructed and that no heated cooling air (e.g. from adjacent plant) is sucked in by the motor.
- Connect the condensate drain piping.
- If the motor is installed in the open the information in the motor operating instructions must be adhered to.

9.1 Electrical connection



Electrical connection may only be carried out by properly qualified staff (electricians).

- In wiring the equipment make sure of the correct (star, delta) connection, voltage level and frequency. In motors with reversible polarity check whether separate or Dahlander windings are used. Refer to the scope of delivery in Appendix A.11.
- A suitable motor protection switch (overcurrent protection) must be installed and wired to prevent overheating due to overload. If this is not included in the scope of delivery then the operator must install same.
- Fans are connected to the electricity supply via a terminal box. Electrical installation must adhere to the motor operating instructions (please refer to same).
- Fans can be switched electrically dead using a maintenance switch (optional) so that maintenance and repair work can be carried out. Refer to the scope of delivery in Appendix A.11.
- If the motor has a positive temperature coefficient thermistor (PTC) then same must be wired up and monitored by a suitable evaluation device.
- Earth fan and motor using the earthing points provided on the fan block.
- Data of the electric equipment installed including the drive motor is given in Appendix A.11.

10 Commissioning



Protective clothing must be worn when commissioning fans.



Check the direction the fan rotor turns. This must agree with the directional arrow on the fan housing.

- Check the motor data on the motor plate.
- Check that the motor is properly earthed.
- Check maximum permissible motor RPM. Compare the maximum motor RPM set with Appendix A.11.
- Check that the piping is completely connected.
- Connect the fan to the electricity supply.



Let it run for about five hours and then check the bearing temperature, power consumption and smoothness of running. Check that the housing is leakproof after 24 hours.

11 Operation



The operator is responsible for fan handling. The operator should install a control panel and possibly an interface to a control system making all due allowance for the fan data.

- Only qualified staff may operate fans.
- The operator is responsible for training and familiarising their staff and drafting local operating instructions.

11.1 Troubleshooting

Troubleshooting may only be undertaken by properly qualified staff.

Fault	Possible causes	Remedial measures
Fan runs rough (oscillations and vibrations)	Changes in the foundation/s and hence major oscillation of the fan	Determine the cause/s of the change/s and remedy them if possible. Check foundation/s and fan and dampen vibrations.
	Rotor out of balance	Balance it. Contact Joh. Mueller Kunststoff GmbH and advise them of the matter.
	Deposits on the rotor	Gently remove dirt and encrustation on the rotor.
	Rotor damage	Damage to the rotor must be remedied. Contact Joh. Mueller Kunststoff GmbH and advise them of the matter.
	Rotor turns the wrong way	Correct it.
	Axial/ radial oscillations of the motor	Check and adjust as needed. Contact Joh. Mueller Kunststoff GmbH and advise them of the matter.

Fault	Possible causes	Remedial measures
Motor overheating	Motor turning the wrong way	Check and correct.
	Motor air supply reduced	Check motor airways. Clean motor.
	Damage to motor windings	Check motor and replace if necessary. Contact Joh. Mueller Kunststoff GmbH and advise them of the matter.
Bearing overheated	Lubricating intervals not adhered to	Lubricate or replace bearings
Fan or motor doesn't start or runs up roughly	Motor overload	Reduce load.
	Interruption of a phase in a motor electricity supply cable	Check switches and wiring.
	Mains voltage too low, frequency too high	Check mains.
	Motor stator winding incorrectly wired	Check motor stator winding.
Low fan performance	Rotor turns the wrong way	Correct it.
	Inlet and/or outlet not leakproof	Check both and remedy leaks.
	Motor stator winding incorrectly wired	Check motor stator winding.
Fan makes a grinding noise	Foreign body between rotor and housing	Remove foreign body.
	Rotor deformed	Check rotor. Contact Joh. Mueller Kunststoff GmbH and advise them of the matter.
Overcurrent protection device (motor protection switch) turns the fan off	Overcurrent protection device (motor protection switch) incorrectly set.	Adjust overcurrent protection device (motor protection switch).
	Motor overload	Check power connection/s.
	Rotor blocked	Check rotor.
	Motor defective	Contact Joh. Mueller Kunststoff GmbH and advise them of the matter.

Fault	Possible causes	Remedial measures
Loss of performance	Elastic sleeving torn / porous / leaky	Check for wear and replace if needed.
	Inlet and outlet piping leaky	Check piping.
Noisy when started or operating	Motor stator winding incorrectly wired	Check motor stator winding and its wiring.
	Winding or phase fault in motor winding	Determine motor winding and insulation resistance, maintenance required. Contact Joh. Mueller Kunststoff GmbH and advise them of the matter.

12 Maintenance, cleaning and repair

12.1 Maintenance and cleaning



Maintenance, cleaning and repair work may only be carried out by properly qualified personnel. Said personnel must be properly trained for the job.



The maintenance, cleaning and repair work must be documented in a "maintenance book" with the date and description of the work performed.



Fans are only to be used if in technically problem-free condition, only for their intended purpose and in compliance with these operating instructions.

- The operator may introduce additional cleaning and maintenance intervals due to fan use.
- If briefer intervals are evidently needed after visual inspection then the operator must introduce same.



Motor maintenance is to be carried out in compliance with the operating instructions provided (refer to motor operating instructions).

- Data of the electric equipment installed including the drive motor is given in Appendix A.11.



We recommend specifying maintenance work in local work instructions. Maintenance is to be carried out and documented in compliance with the checklist in Appendix A.1.



Make sure that switching the fan electrically dead does not involve any risk in or to the plant as a whole.



The motor must be electrically dead before work is carried out on a fan and also protected against unauthorised / unintentional switching on by a maintenance switch with lock.

- Before carrying out maintenance, cleaning or repair work the possible risks emanating from the fan/s or from the activities involved must be evaluated and appropriate measures taken (by the operator).

Possible risks here include those below.



Hot surfaces



Risk of crushing



Risk of ingestion



Danger due to electricity

- Identify the spare parts on the basis of the type plate and technical documentation. Then consult the customer service department of Joh. Mueller Kunststoff GmbH on the subject.

12.2 Carrying out maintenance work

The maintenance and service work needed is detailed in the table below with the associated intervals. Note that the intervals must possibly be shortened if gasses contain dust or chemicals.

The motor roller bearings are lubricated for life in standard versions. The service life is calculated to be 10,000 to 20,000 operating hours. If the option with later manual lubrication is chosen then the motor performance plate data must be complied with (see motor operating instructions).

The intervals are based on constant fan operation. If it only runs occasionally the intervals can be lengthened accordingly. Note that the bearings are under load even when the fan is switched off.

Preparation	
1	The fan motor must be electrically dead.
2	The main switch must be secured against unauthorised use.
3	Wait until the fan rotor stops (at least 3 minutes after being switched off).
4	Wear personal protective equipment.
Weekly visual inspection	
5	Type and warning plates must be clearly legible. Clean them if necessary.
6	Gently remove dirt and encrustation on the rotor. Imbalance due to deposits on the rotor may lead to the destruction of the device.
7	Other contamination (e.g. on housing) must be removed.
8	Check the fluid drain on the spiral housing for blockage/s.

9	 Check rotor for smooth running. If unusual vibration occurs or the rotor turn roughly then the fan must be stopped immediately and not used until the cause has been remedied. Such remedy may only be carried out by properly qualified Joh. Mueller Kunststoff GmbH staff.
Monthly visual inspection	
10	Check fan and motor are securely fixed and fastened in place. If necessary tighten fastenings and fixtures.
11	Check piping, housing and housing cover for leaks.

Monthly visual inspection continued	
12	<p>Check elastic elements such as vibration dampers and connection bushings for wear and tear. If they're damaged or have become porous replace them immediately.</p> <p>Check earthing for function.</p>
Annual visual and fundamental inspection	
13	<p>The rotor must be removed for the fundamental inspection and cleaning.</p> <p>Undo the fan's suction side piping and open the rotor cover.</p> <p>Undo the tapered tensioning elements and remove the rotor - without extractor - through the suction side installation aperture.</p> <p>Clean it thoroughly, including housing interior if needed.</p> <p>Inspect the rotor for damage and deformation.</p> <p>Inspect the housing for damage.</p> <p>Check the quiet and smooth running of the rotor after reinstalling it.</p> <p>Reinstall the rotor cover and connect the fan to the suction side piping before starting the fan.</p> <p>After basic cleaning the fan must be recommissioned in compliance with Chapter 1010.</p>
14	<p>Check earthing point conductivity.</p>
Motor maintenance	
15	<p>See motor operating instructions.</p>

Table 4. Maintenance and service work to be rendered and their intervals.

The operator can adjust these intervals to allow for the level of contamination.

12.3 Repair



For safety reasons the fan may only be repaired using original spare parts and in agreement with Joh. Mueller Kunststoff GmbH.

The spare parts can be identified on the basis of the type plate data or the technical documentation. Then consult the customer service department of Joh. Mueller Kunststoff GmbH using this information.

The fan must be recommissioned in compliance with Chapter 10 after repair10.

13 Warranty / guarantee

We cannot accept any liability whatsoever for damage due to not adhering to the foregoing instructions.

A.1 Maintenance checklist

Preparation			
1	Switch the drive electrically dead.	<input type="checkbox"/>	
2	Secure the main switch against use.	<input type="checkbox"/>	
3	Wait for the rotor to stop - this takes about three minutes.	<input type="checkbox"/>	
4	Wear personal protective equipment.	<input type="checkbox"/>	
Weekly visual inspection			
		Yes	
		No	
5	Type and warning plates clearly legible: No. Description and measures taken:	<input type="checkbox"/>	<input type="checkbox"/>
6	Rotor dirt and encrustation: Yes. Description of contamination and cleaning Gently clean the rotor.	<input type="checkbox"/>	<input type="checkbox"/>
7	Other contamination (e.g. on housing) Yes. Description of contamination and cleaning	<input type="checkbox"/>	<input type="checkbox"/>
8	Check the fluid drain on the spiral housing for blockage/s.	<input type="checkbox"/>	<input type="checkbox"/>
9	Check smooth and quiet running of the rotor. Imbalance? Vibrations? Yes. Shut the fan off and lock it in that mode immediately. Consult Joh. Mueller Kunststoff on remedying the problem. If no then give details of further measures.	<input type="checkbox"/> <input type="checkbox"/> <input type="checkbox"/>	<input type="checkbox"/> <input type="checkbox"/> <input type="checkbox"/>
Monthly visual inspection			
10	Check fan and motor are securely fixed and fastened in place. If necessary tighten fastenings and fixtures.	<input type="checkbox"/> <input type="checkbox"/>	<input type="checkbox"/> <input type="checkbox"/>
11	Check for leaks: Piping Housing Housing cover	<input type="checkbox"/> <input type="checkbox"/> <input type="checkbox"/>	<input type="checkbox"/> <input type="checkbox"/> <input type="checkbox"/>

Monthly visual inspection continued			
12	Check elastic elements for wear and tear.		
	12 a) Vibration dampers OK	<input type="checkbox"/>	<input type="checkbox"/>
	12 b) Connecting bushings OK	<input type="checkbox"/>	<input type="checkbox"/>
	12 c) Rotor OK	<input type="checkbox"/>	<input type="checkbox"/>
	If not: Replace element.		
13	Check earthing for function.	<input type="checkbox"/>	<input type="checkbox"/>
Annual visual inspection and basic cleaning			
14	Basic inspection and cleaning of the rotor:		
	Undo the fan's suction side piping.	<input type="checkbox"/>	<input type="checkbox"/>
	Open the rotor cover.	<input type="checkbox"/>	<input type="checkbox"/>
	Undo the tapering tensioning element.	<input type="checkbox"/>	<input type="checkbox"/>
	Extract the rotor through the installation aperture.	<input type="checkbox"/>	<input type="checkbox"/>
	Thoroughly clean the rotor.	<input type="checkbox"/>	<input type="checkbox"/>
	Clean the housing interior if needed.	<input type="checkbox"/>	<input type="checkbox"/>
	Inspect the rotor for damage and deformation.	<input type="checkbox"/>	<input type="checkbox"/>
	Inspect the housing for damage.	<input type="checkbox"/>	<input type="checkbox"/>
	Check the quiet and smooth running of the rotor after reinstalling it.	<input type="checkbox"/>	<input type="checkbox"/>
	Reinstall the rotor cover and connect the fan to the suction side piping.	<input type="checkbox"/>	<input type="checkbox"/>
	Details of contamination:		
	After basic cleaning the fan must be recommissioned in compliance with Chapter 10.		
15	Check earthing point conductivity.	<input type="checkbox"/>	<input type="checkbox"/>
Motor maintenance			
16	See motor operating instructions.		

A.2 ML 160 performance data

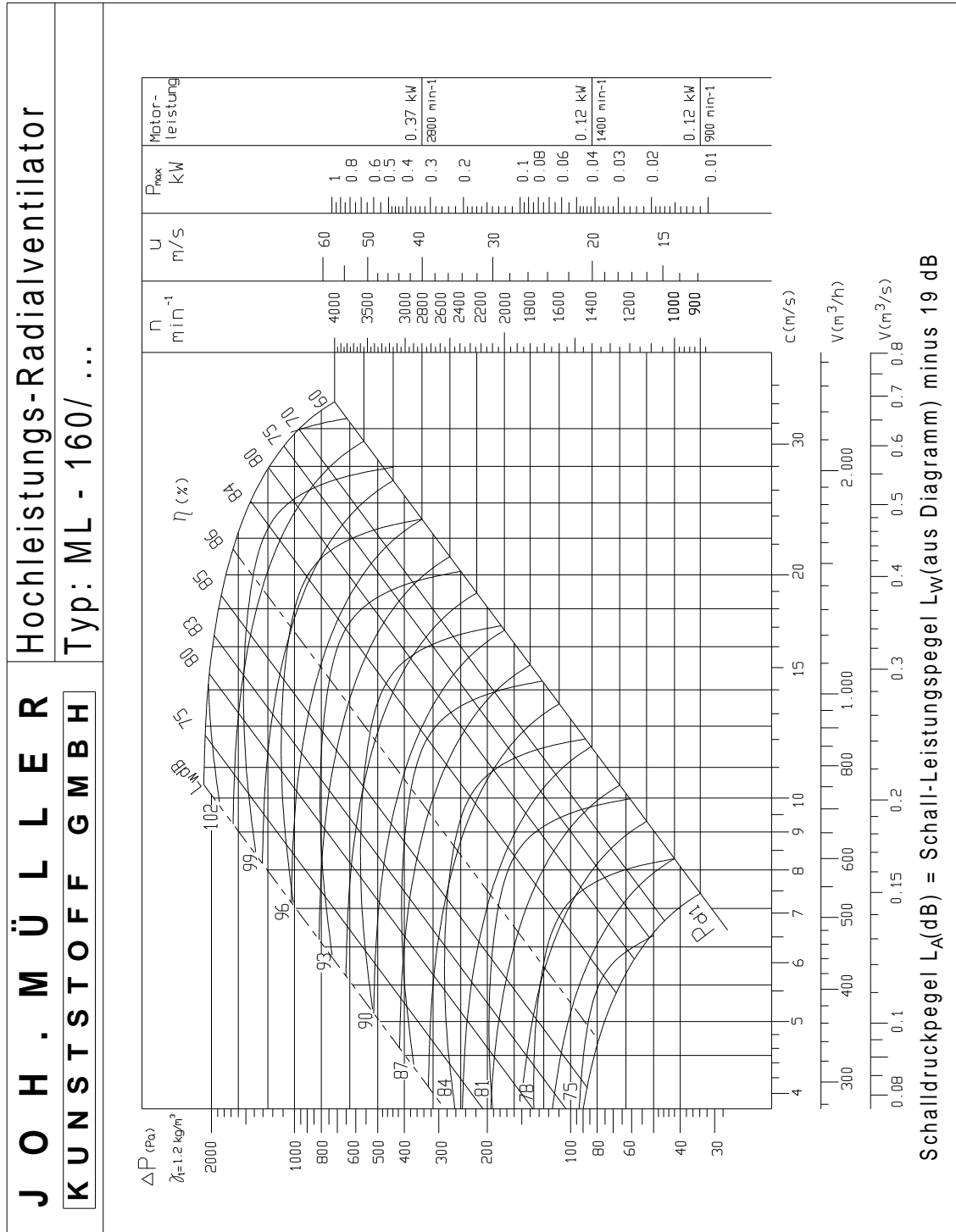

A.3 ML 180 performance data

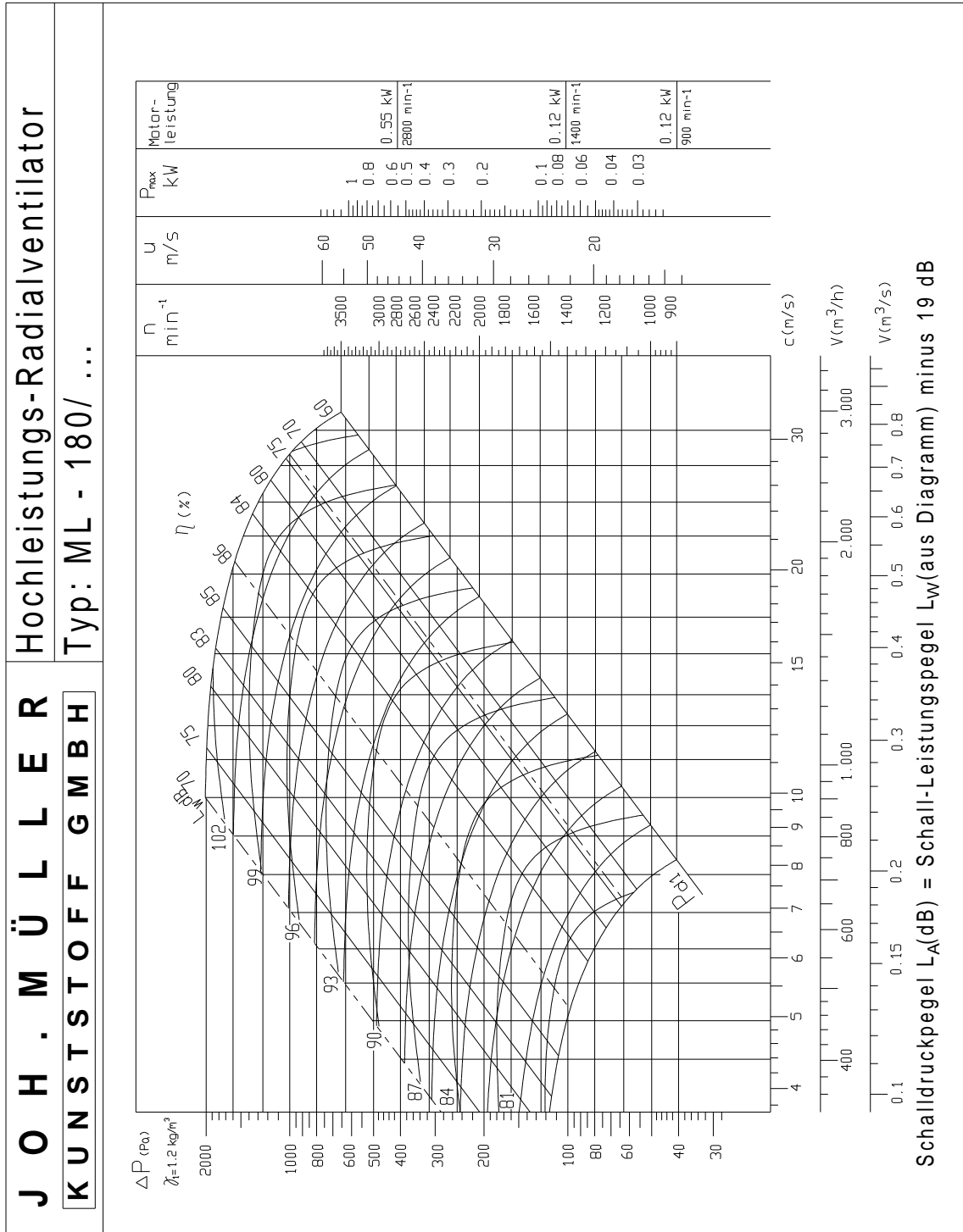

A.4 ML 200 performance data

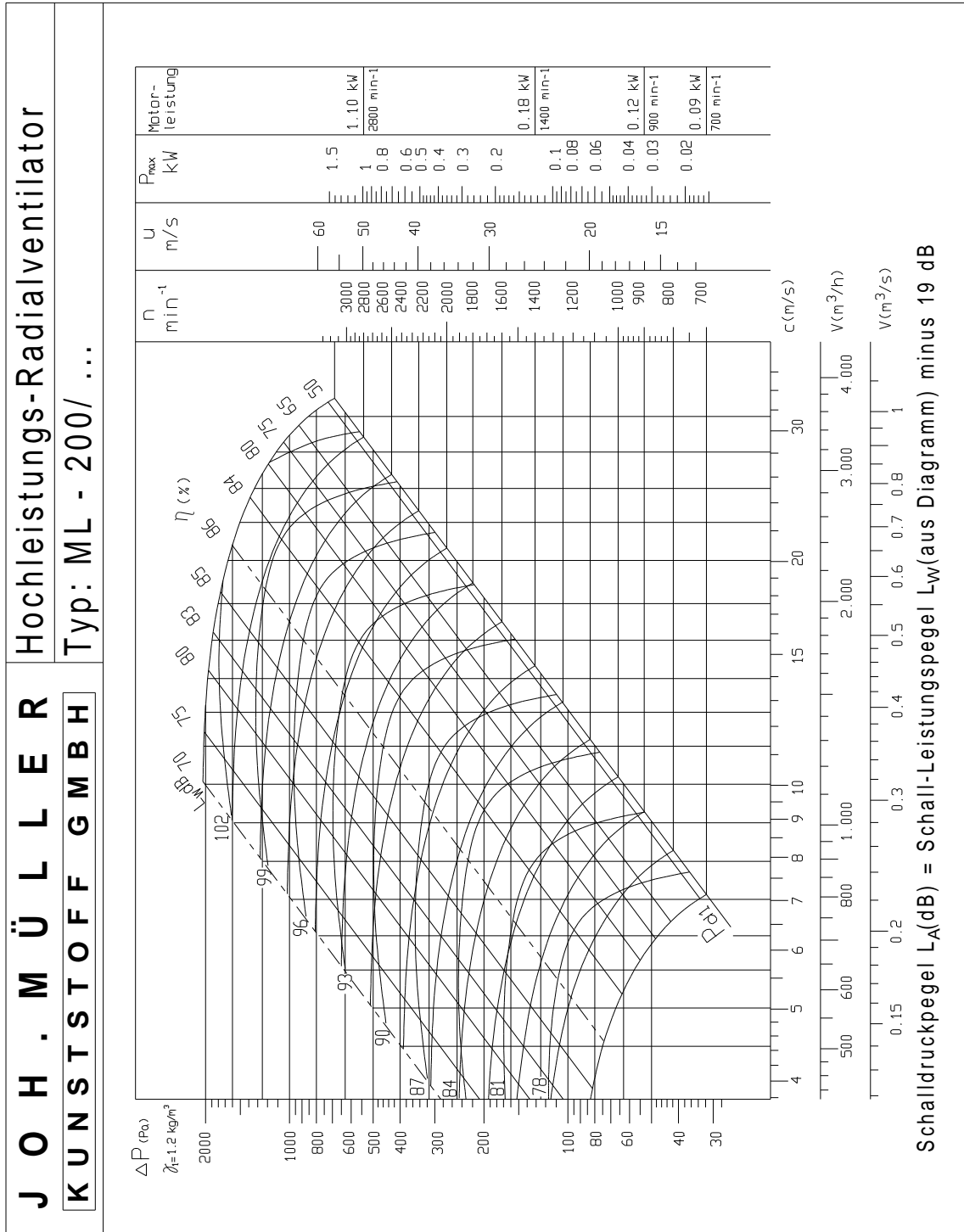

A.5 ML 225 performance data

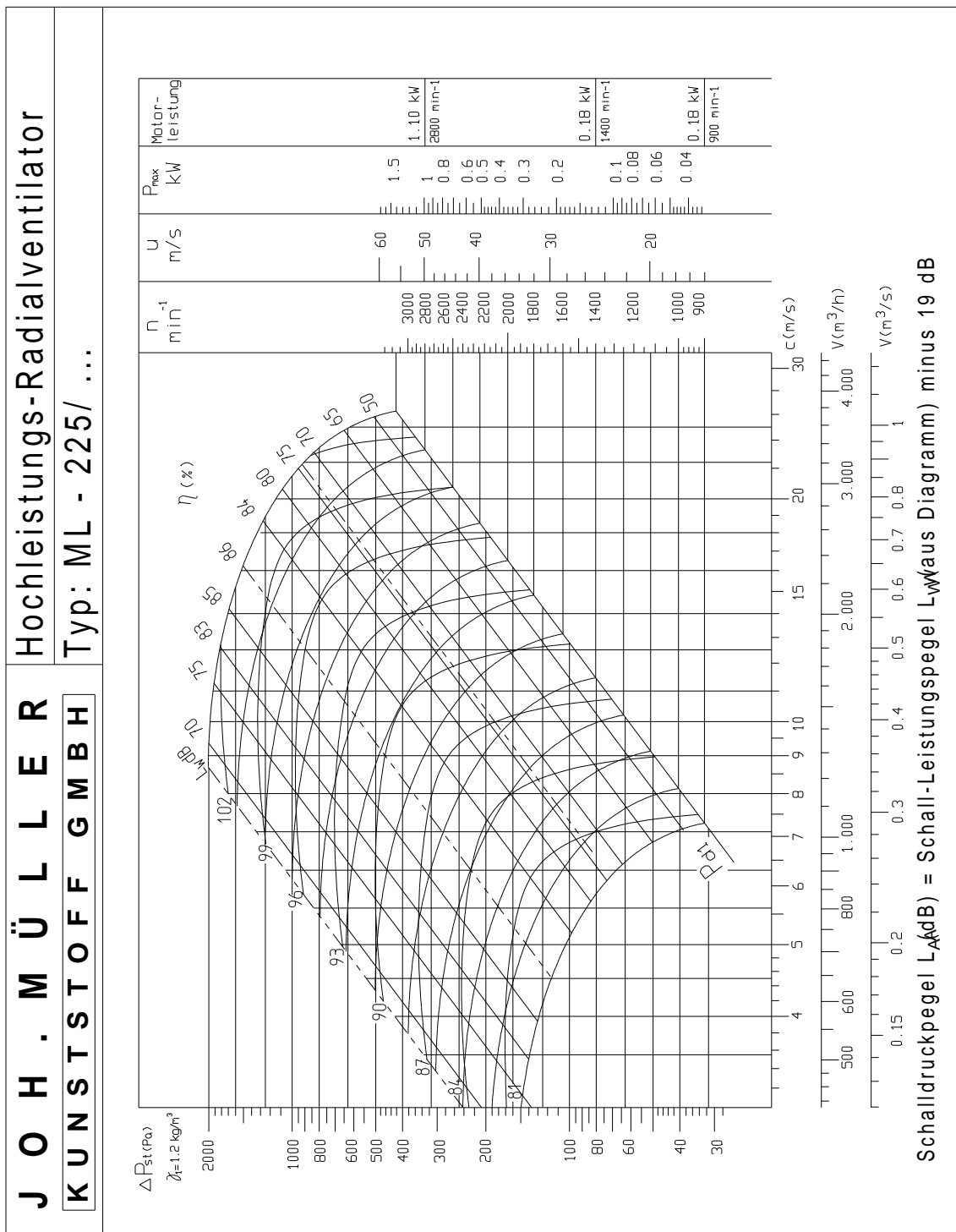

A.6 ML 250 performance data

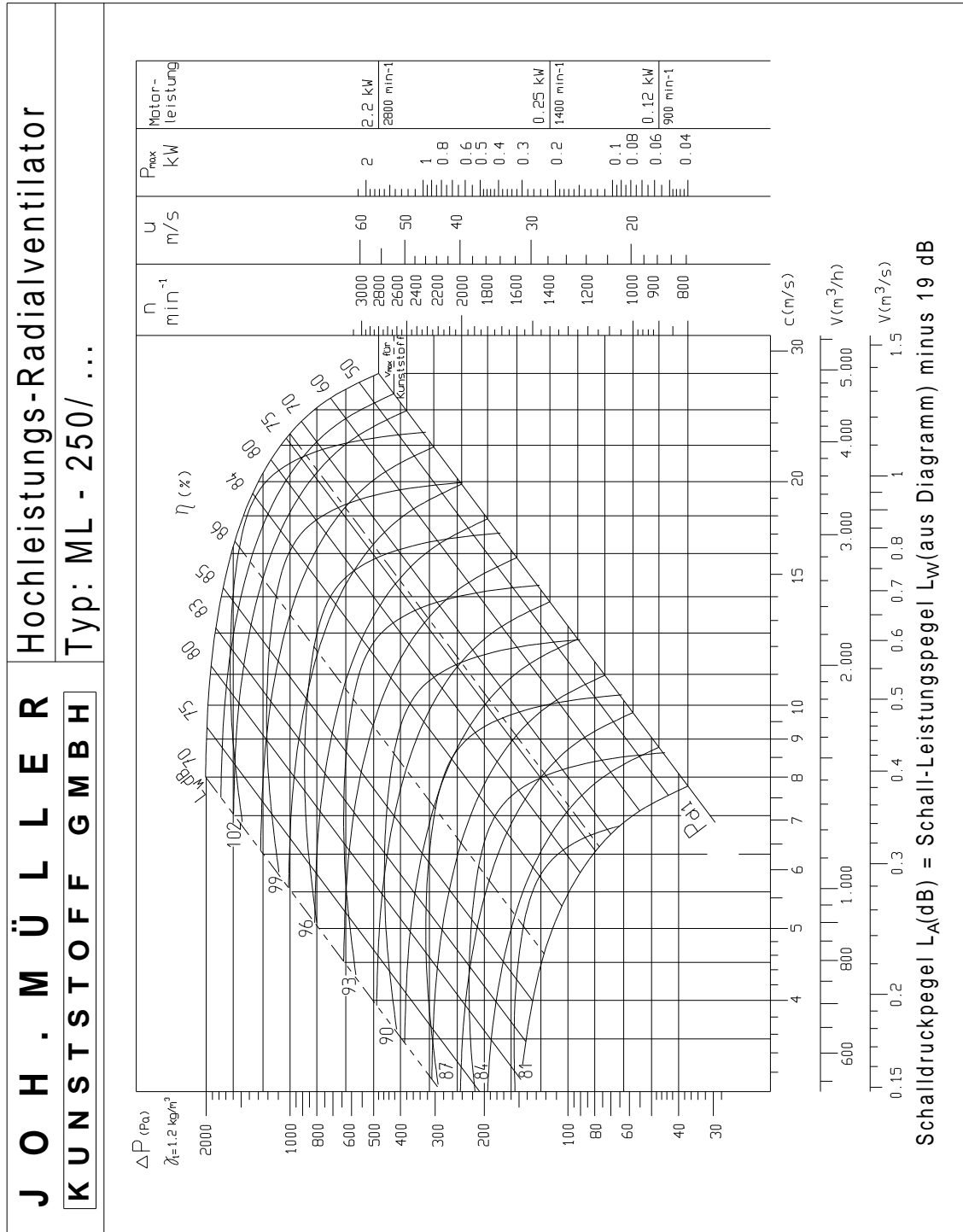

A.7 ML 280 performance data

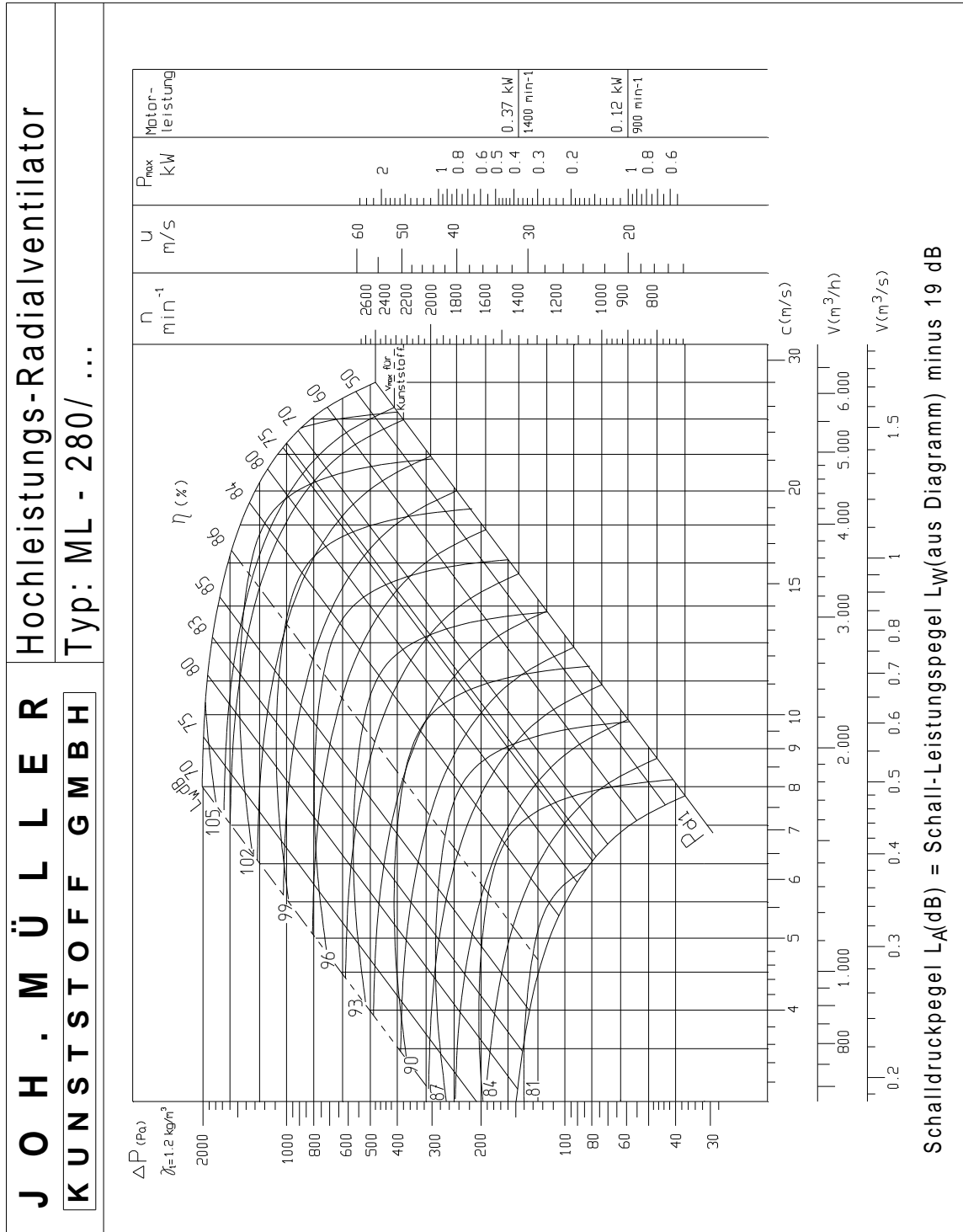

A.8 ML 315 performance data

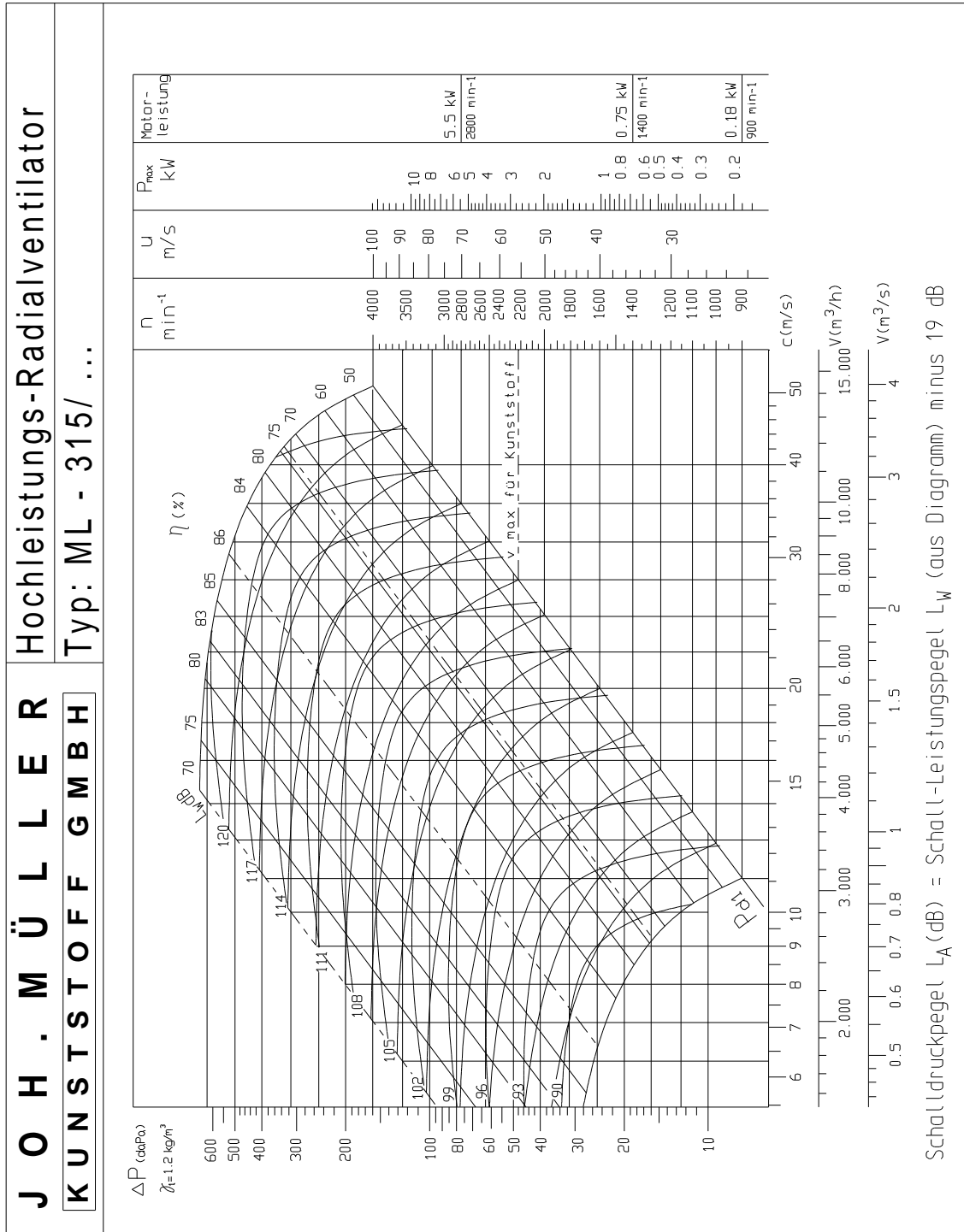

A.9 ML 355 performance data

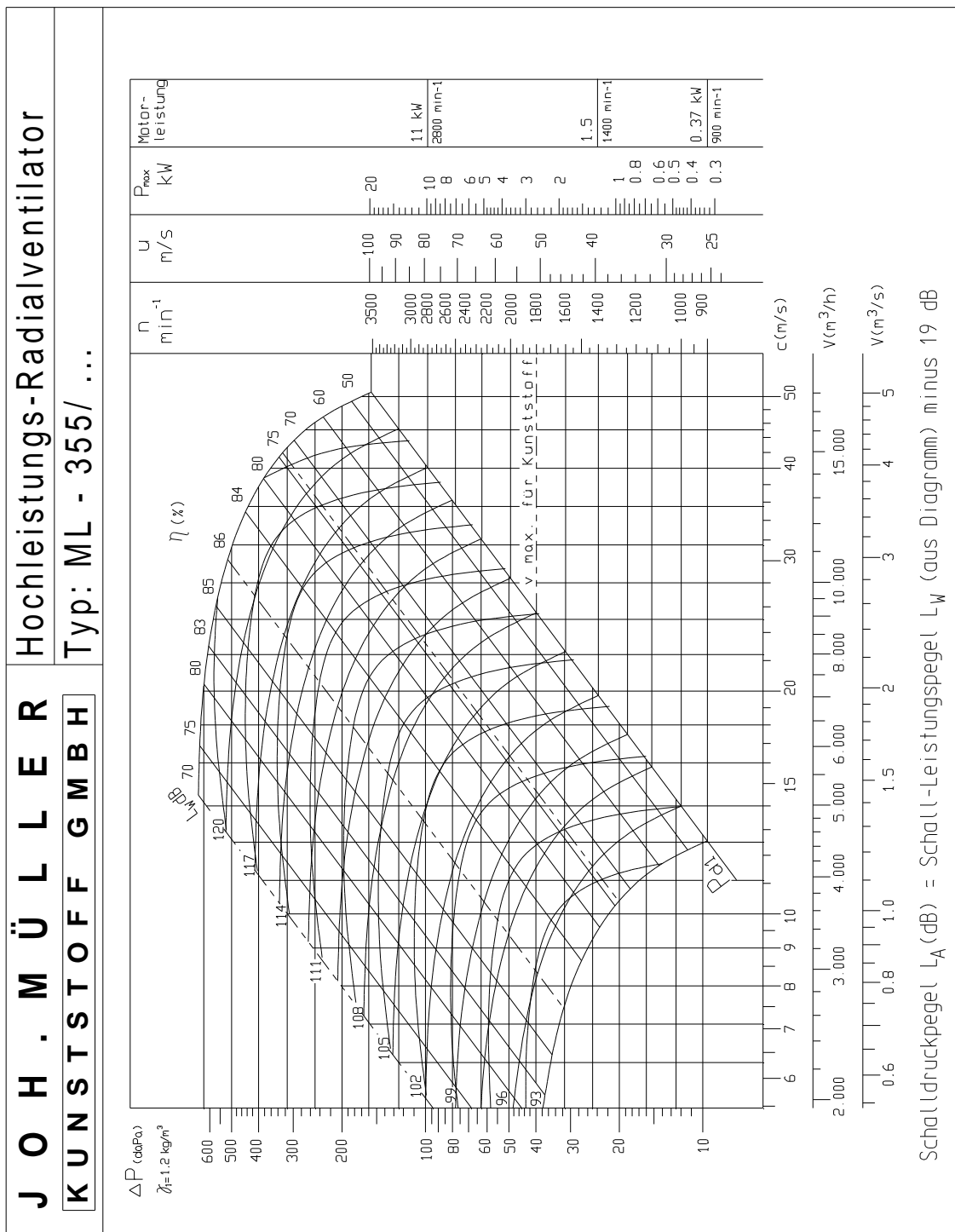

A.10 ML 400 performance data

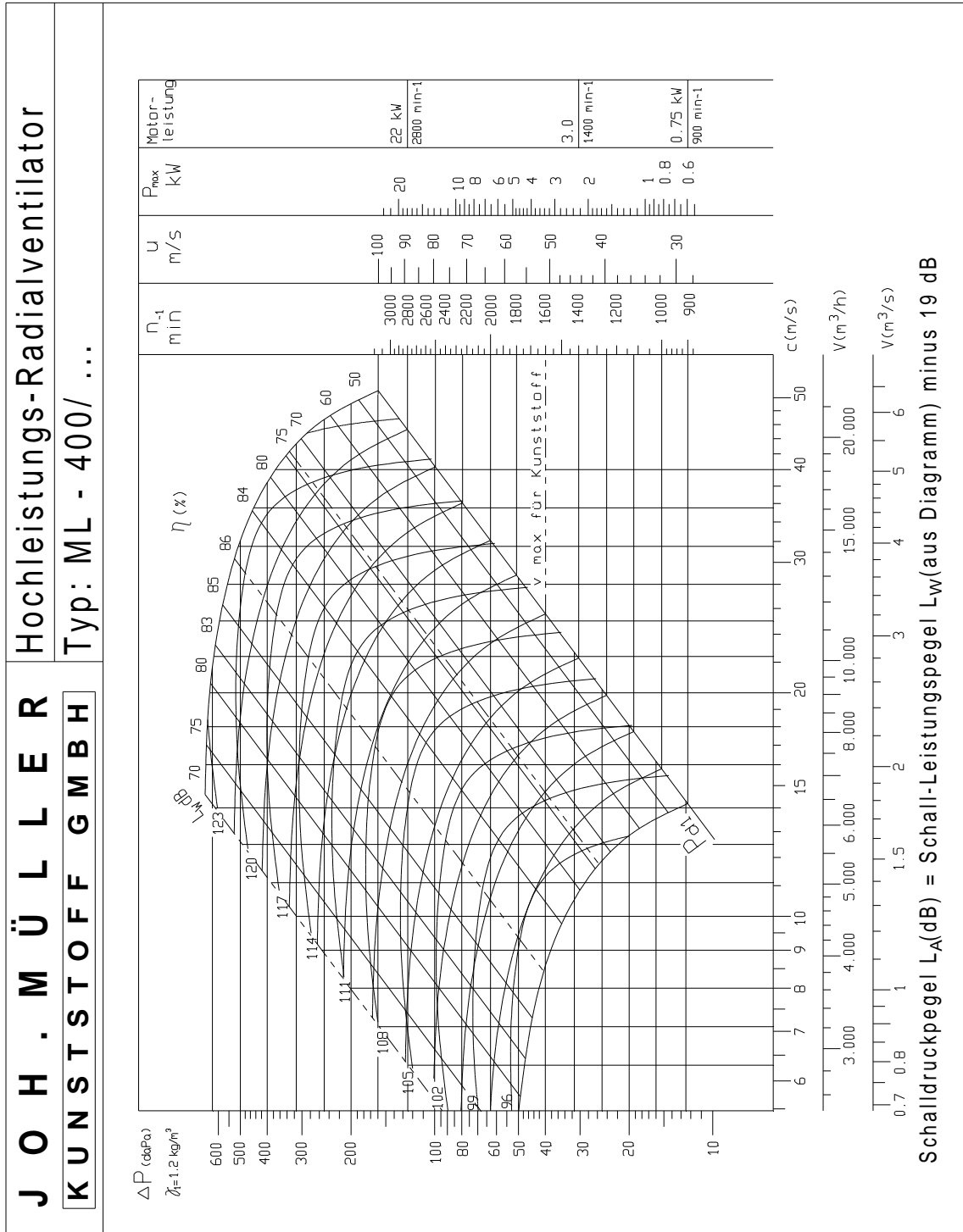

A.11 Scope of delivery

JOH. MÜLLER

KUNSTSTOFF GMBH

JOH. MÜLLER

KUNSTSTOFF GMBH

JOH. MÜLLER

KUNSTSTOFF GMBH

JOH. MÜLLER

KUNSTSTOFF GMBH

JOH. MÜLLER

KUNSTSTOFF GMBH

A.12 Notes

JOH. MÜLLER
KUNSTSTOFF GMBH

Lescheider Weg 6-8 · D-53773 Hennef-Bierth

Tel. +49-2248-9173-0 · Fax +49-2248-9173-79

E-mail info@kunststoff-mueller.de

www.kunststoff-mueller.de